

SH320240C (320 DOTS X 240 DOTS)

FEATURES

- BUILT-IN CONTROLLER (RA8835 OR EQUIVALENT)
- +5 V POWER SUPPLY
- 1/240 DUTY CYCLE
- 8-BIT PARALLEL INTERFACE

MECHANICAL DATA

ITEM	DIMENSIONS	UNIT
Module Size (W x H x T)	148.0 x 120.2 x 20.5	mm
Viewing Area (W x H)	120.14 x 92.14	mm
Active Area (W x H)	115.17 x 86.37	mm
Dot Size (W x H)	0.33 x 0.33	mm
Dot Pitch (W x H)	0.36 x 0.36	mm

INTERFACE PIN CONNECTIONS

NO.	SYMBOL	LEVEL	FUNCTION
1	V _{SS}	0V	Power Supply Ground
2	V _{DD}	5V	Power Supply Voltage
3	V ₀	-	Contrast Adjustment Voltage
4	/RD	L	Read Signal
5	/WR	L	Write Signal
6	A ₀	H/L	Data Type Select
7~14	DB0~DB7	H/L	Data Bus Line
15	/CS	L	Chip Signal
16	/RES	H/L	Reset Signal
17	V _{LCD}	-	Power Supply Voltage For LCD
18	FG	-	For GND
19	NC	-	No Connection
20	NC	-	No Connection

ABSOLUTE MAXIMUM RATINGS

ITEM	SYMBOL	MIN.	TYP.	MAX.	UNIT
Supply Voltage For Logic	V _{DD} -V _{SS}	0	-	7	V
Supply Voltage For LCD Drive	V _{DD} -V ₀	0	-	30	V
Input Voltage	V _I	V _{SS}	-	V _{DD}	V

ELECTRICAL CHARACTERISTICS

ITEM	SYMBOL	CONDITION	MIN.	TYP.	MAX.	UNIT	
Supply Voltage For Logic	V _{DD} -V _{SS}	-	4.5	5	5.5	V	
LCD Supply Voltage	V _{DD} -V ₀	V _{DD} =5V Ta=25	22.4	23.5	24.3	V	
Supply Current	I _{DD}	V _{DD} =5V	-	16	25	mA	
Input Voltage	"HIGH" Level	V _{IH}	-	2.2	-	V _{DD}	V
	"LOW" Level	V _{IL}	-	-	-	0.6	V
Output Voltage	"HIGH" Level	V _{OH}	-	2.4	-	V	V
	"LOW" Level	V _{OL}	-	-	-	0.4	V

EXTERNAL DIMENSIONS

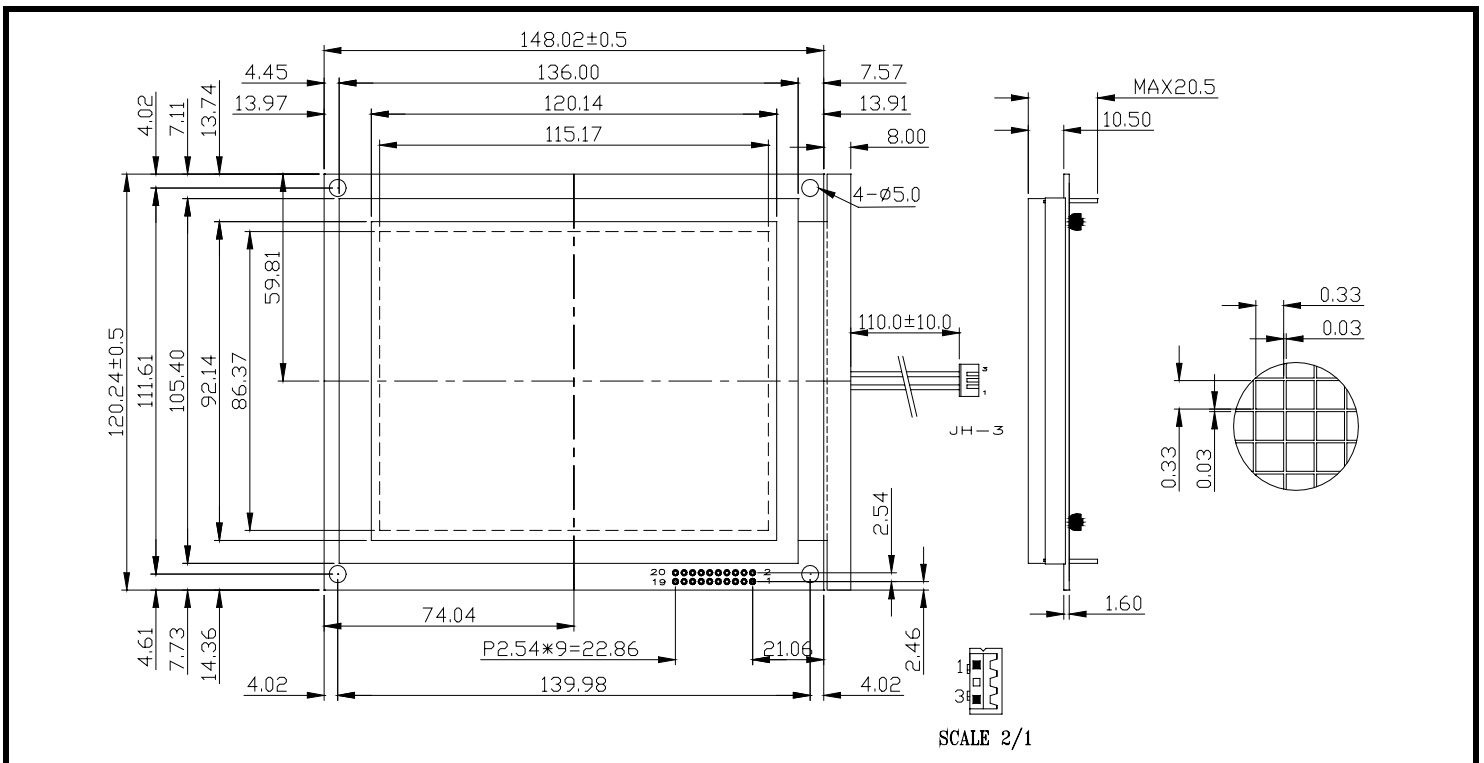

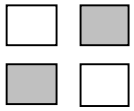

SH320240C (320 DOTS X 240 DOTS)

TIMING CHARACTERISTICS

ITEM	SYMBOL	MIN.	TYP.	MAX.	UNIT.
System Cycle Time	t_{CYC}	425	-	-	ns
Address Set-up Time	t_{AW}	30	-	-	ns
Address Hold Time	t_{AH}	10	-	-	ns
Data Set-up Time	t_{DS}	120	-	-	ns
Data Hold Time	t_{DH}	10	-	-	ns
Output Disable Time	t_{OH}	10	-	50	ns
Access Time	t_{ACC}	-	-	120	ns
Enable Pulse Width	Read	t_{EW}	-	-	ns
	Write				

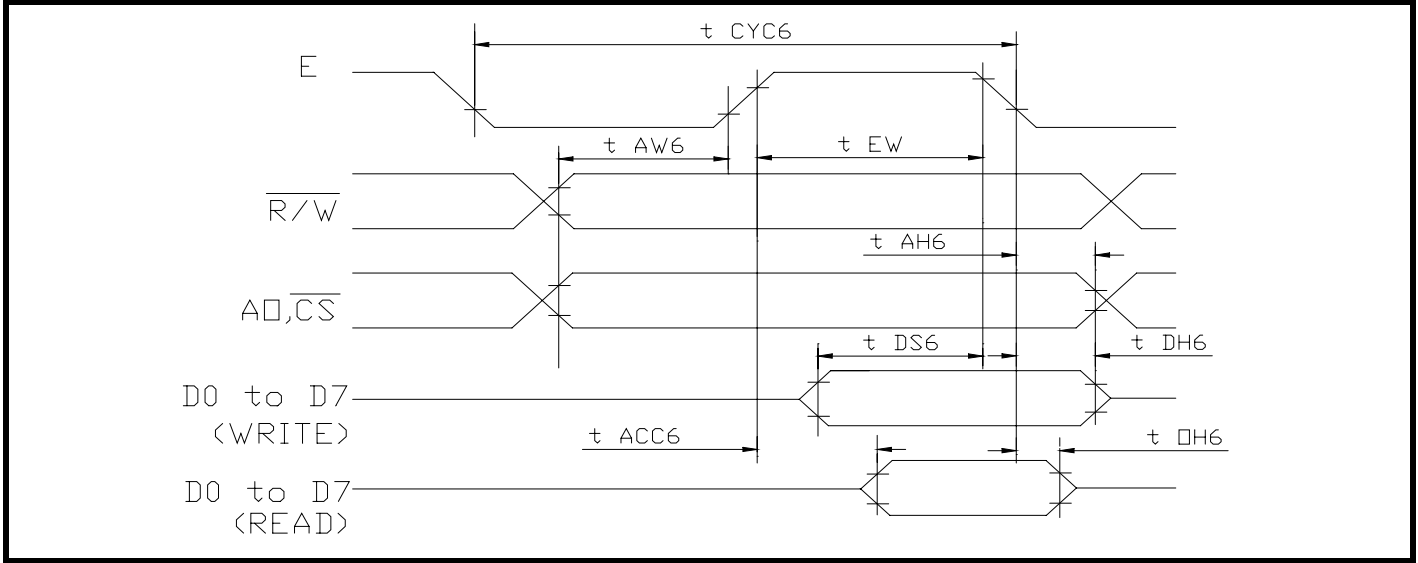

BLOCK DIAGRAM

